

Auction Catalogue
Auction conducted by mjunction services ltd
**SALE OF INDUSTRIAL BY-PRODUCTS MANAGEMENT DIVISION MATERIALS OF
TATA STEEL LIMITED, SAHIBABAD /UP / Miscellaneous Scrap & Iron
Oxide being sold on “AS-IS-WHERE-IS” and “NO-COMPLAINT” basis**

| | |
|-------------------------|---|
| Mandate Number: | VJ24874725 |
| Seller: | Tata Steel Limited, SAHIBABAD |
| Auction website: | https://www.metaljunction.com |
| e-Auction Date & Time: | 29 July 24 AT 02:00 PM |
| Inspection Date & Time: | Till 29 July 24 till 11 AM |

| | | |
|-----------------------------------|-------------------------------|--|
| Contact Details Mjunction Ltd. | Category Manager | Mr. Siddharta Jana-7596075766 , Mr. Saroj kr Das - 6290822107 |
| | Auction Room No. | 033 – 66031760-61, 033 – 66031763-72, 033 – 44091760-61, 033 – 44091763-72 |
| | Contact person for Inspection | «\$attributeObject.get(\$!681)» |

CONTACT DETAILS FOR TATA STEEL LIMITED-SAHIBABAD POST SALES MNGT SYSTEM AT MJUNCTION.

| POST AUCTION RELATED CONTACT DETAILS | Landline No | Email id |
|--|---|---|
| Lot Confirmation Related | 033-4409-1801 | tsmpsms@mjunction.in |
| Money Receipt Section / Payment Related | 033-4409-1802 | tsmpsms@mjunction.in |
| Material Value Refund Related | 033-4409-1805 | tsmpsms@mjunction.in |
| Delivery Order Related | 033-4409-1804 | tsmpsms@mjunction.in |
| Concessional TCS Forms Related | 033-4409-1801 | tsmpsms@mjunction.in |
| Collection of Delivery Order for Tata Steel-Sahibabad | 8100202615 | tsmpsms@mjunction.in , Kumar.Tulit@mjunction.in |
| For time bound resolution of unresolved issues log into our customer care portal | Type in www.metaljunction.com > Go to “Important Links” > Click on “Customer Complaints”> Log in with your user id and password and write the details of issue | |
| For Any unresolved Issues at Mjunction, SAHIBABAD | Aditya Singhal (Aditya.Singhal@mjunction.in)7596058570 (From Monday to Friday Only on in working hours) | |
| | | |
| | | |

Auction room’s e-mail address : metal.auctionteam@mjunction.in

| | |
|----------------------------|---|
| For Commercial Issue | Mr. Govind Sharma Mr. Santosh Agrawal : 9811798100 sagrawal@tatasteel.com |
| For Delivery related issue | Mr. Govind Sharma Mr Santosh Agrawal : 9811798100 sagrawal@tatasteel.com |

Field Service Delivery Contact details for any queries:

| SI No | FSD | Indicative Territory | Contact Details | Email ID |
|-------|-------------------|---|-----------------|--|
| 1 | Akash Chakraborty | West Bengal, Assam & other Northeast Region | 7605090372 | chakraborty.akash1@mjunction.in |
| 2 | Kamlesh Verma | Rajasthan, Punjab, Haryana, Himachal Pradesh, Jammu & Kashmir | 7605090375 | verma.kamlesh@mjunction.in |
| 3 | Khizer Fakhir | Maharashtra, Gujarat & Goa | 9147178852 | fakhir.khizer@mjunction.in |
| 4 | Mitesh Giradkar | Chhattisgarh & Madhya Pradesh | 7596040406 | mitesh.giradkar@mjunction.in |
| 5 | Prabhat Singh | Delhi, Uttar Pradesh & Uttarakhand, | 7596059533 | prabhat.singh@mjunction.in |
| 6 | Srinivas R | Karnataka, Tamil Nadu, Kerala, Andhra Pradesh & Telangana, | 8777487843 | srinivas.r@mjunction.in |
| 7 | Satish Kumar | Odisha | 9147074862 | satish.kumar1@mjunction.in |
| 8 | Suvanil Mukherjee | Bihar & Jharkhand | 9147018225 | mukherjee.suvanil@mjunction.in |
| 9 | Kulkant Shukla | FSD Team Coordinator (All Region) | ----- | kulkant.shukla1@mjunction.in |

INSPECTION PROTOCOL

1. Buyer's generate Inspection request ID by Self Service through Visitor pass Link https://webapp01.tatasteel.co.in/VGP/reg_login_screen.aspx.
2. Otherwise, request shall not entertained.
3. Mandatory Requirement for buyer for Inspection Personal Protective Equipment's (PPE) i.e., Safety Shoes, Safety Helmet, Safety Goggles, Fluorescent Jacket and Hand Gloves.
4. Inspection request has to be send one day before the day of Inspection in working hours or latest by 5:00 PM.
5. Saturday & Sunday Inspection request will not entertained.
6. Buyer may forwarded inspection visitor request id to email id tmspsms@mjunction.in; Aditya.Singhal@mjunction.in Pankaj.rajput@mjunction.in
7. Buyer may contact for the Inspection of Material
 1. MJ:- Aditya Singhal ([7596058570](tel:7596058570)) Pankaj Rajput ([9953314085](tel:9953314085))
 1. TSL:- Mr Piyush Bali :- 8076098709
Mr Santosh Agrawal : 9811798100

New Safety Norms and Checklist for HMV/LMV

| S.No. | Work | Work related hazards/impact | Responsibility | Process / PPEs (How) | Remarks/References |
|-------|-------------------|---|---------------------------|---|--------------------|
| 01 | General Awareness | <p>Safety:</p> <ul style="list-style-type: none"> Unaware of dangers of steel plant Unaware of use of PPEs Unaware of Tata Steel's Safety Standards Unaware of workplace hazards Unaware of Covid-19 virus <p>Environment:- Not Applicable</p> <p>Quality:- Not Applicable</p> | Transport park Supervisor | <ul style="list-style-type: none"> Ensure that all drivers/lifters are trained on safety and the records are well maintained | |
| | | | All workers | <ul style="list-style-type: none"> Be sure to use PPE such as a safety helmet, safety shoe, safety goggles, fluorescent jacket, dust mask. Check all PPE before inspection Replace the faulty one immediately. Ensure that COVID 19 guidelines such as social distancing, travel history, temperature check and use of face masks are followed. | |
| | | | Driver of the vehicle | <ul style="list-style-type: none"> Keep the required documents | |

| | | | | | |
|----|-----------------------|--|--|---|--|
| 02 | Checking of documents | | | <p>Verification of documents like Driving License, Driver's Aadhar Card/Voter Card, PPE, Vehicle Registration Card/Book, Pollution Test, Permit, Road Tax, Vehicle Fitness, Vehicle Parking Slip, Work Order/DO Copy, Covid Test and Eye Test Certificate</p> | |
| | | | | <ul style="list-style-type: none"> • Entry of details in the register • Revealing the veracity of the documents to the vehicle security checking team. | |

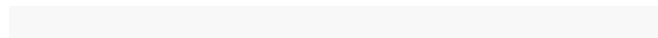
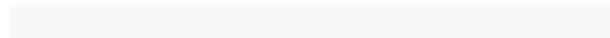

| | | | | | |
|-----|-----------------------------|---|----------------------------------|---|--|
| 03. | <p>Vehicle safety check</p> | <p>Safety:</p> <ul style="list-style-type: none"> • Car collision • Run over • Vehicle rolling • Slip/Trip/Fall <p>Environment: N/A</p> <p>Quality: N/A</p> | <p>Transport park Supervisor</p> | <ul style="list-style-type: none"> • Get the details of the vehicle checked from the document verification team • Proceed to the parking lot for security check using the barricaded path. • Make sure to use proper PPE as per the standard. • Follow all road safety rules. • Vehicles are to be checked as per Vehicle Checklist. <p>(Form no SHE/WP/RRM/FOR/16)</p> <ul style="list-style-type: none"> • It is to be ensured that no modification of vehicle body or cabin so as to add storage tanks, container etc which can interfere with gross tare weight by adding or emptying the liquid in it before gross/tare and thus interfere with net weight. • Do not use mobile in parking and during vehicle checking. • Do not check vehicles parked in no parking areas and outside the parking lot. • During inspection ensure proper body condition of the vehicle and scotch block in the wheels | |
|-----|-----------------------------|---|----------------------------------|---|--|

| | | | | | |
|-----|---|---|---------------------------|--|--|
| | | | | <ul style="list-style-type: none"> • Maintain a safe distance from previously checked vehicles. • If the vehicle is found to be fine as per the checklist (tyres, blinkers, back camera, head light, back horn etc.), the completed checklist may be handed over to the driver/lifter. • If the vehicle is not found in good condition, then checklist with proper remarks is to be given to the concerned driver/lifter for rectification and re-examined after rectification. • Ensure that no vehicle is checked more than twice in a day | |
| 04. | Safety training to driver and issue of security pass and photo pass to driver | <p>Safety:</p> <ul style="list-style-type: none"> • Safety training to drivers • Workplace Safety <p>Environment: N/A Quality: N/A</p> | Transport park Supervisor | <ul style="list-style-type: none"> • Check Vehicle Safety Checklist issued by Vehicle Safety Checking Agency • If vehicle is fine as per check list then proceed for driver safety training. • Make sure that the concerned driver has verified vehicle check list, Aadhar/Voter card, driving license, vehicle parking slip, work order/DO copy, | |

| | | | | | |
|--|--|--|--|--|--|
| | | | | <p>eye check certificate and proper PPE before making security pass.</p> <ul style="list-style-type: none">• Driver is fit to drive the vehicle.• Drivers should be shown safety videos.• Following guidelines for mobile usage to be given to Drivers:<ul style="list-style-type: none">○ Heavy Vehicle /Mobile crane /HEMM drivers should keep his mobile in switch off or silent mode while on driving seat. Mobile phone should only be used after stopping the vehicles appropriately . (Cell Phone/Mobile phone signifies any device that makes or receives phone calls, sends text messages, surfs the Internet, or downloads and allows for the reading of and responding to email, whether the device is company owned or personally owned. Earphones / Headphones / Hands free / Bluetooth enabled hearing devices will be considered a part of Cell Phone. It also includes any type of music/ gaming device such as iPods, Portable Music through earphone etc.)• Make sure the driving license is verified through the Mparivahan App. | |
|--|--|--|--|--|--|

| | | | | | |
|----|------------------------------------|--|---------------------------|--|--|
| | | | | <ul style="list-style-type: none"> The photo pass (entry gate pass) should be made and handed over to the concerned driver only after security training, verification of ID (Aadhaar/Voter Card, Driving License, Security Pass, Vehicle Parking Slip) of the concerned driver and verification of registration number of the concerned vehicle and verified checklist as well as DO copy for IBMD vehicle and for supply/store car | |
| 05 | Issuance of loading advice and GPS | <p>Safety: NA</p> <p>Environment: NA</p> <p>Quality: N/A</p> | Transport park Supervisor | <ul style="list-style-type: none"> loading advice to be made only after checking paper like DO copy, vehicle safety verified checklist, lifter authority etc. Entry of DO number in TSL(IBMD IS) system. Check DO details in the system If found correct, print out the loading advice to be given after entering the loading location as mentioned in the DO After mapping the loading location, GPS should be given as per the loading advice issued to the driver. | |

| | | | | | |
|-----|-------------------------|--|--|---|--|
| 06. | Emergency preparedness. | <p>Safety:</p> <p>Bodily injury to any worker during the course of work.</p> <p>Environment: N/A</p> <p>Quality: N/A</p> | All Tata Steel workers and contract wokers | <p>In case of any emergency, immediately inform the following concerned agencies clearly mentioning the exact location of the incident. • Hire one person as a guide, who will escort the agencies to the right location if the location is a bit internal.</p> <p>• Keep a fire extinguisher and first aid box in the office</p> <p>TSL Emergency no.: - 0657 66 47777</p> <p>Fire Brigade – 06572645101</p> <p>First aid (East) – 0657 66 43214</p> <p>First aid (West) – 0657 66 43412</p> <p>Security officer – 9204652485</p> <p>Manager MRD- 9234500733 (Mobile)</p> <p>Sr. Manager MRD- 9040094833 (Mobile)</p> <p>Head (MR & SPP) – 9204058272 (Mobile)</p> | |
|-----|-------------------------|--|--|---|--|

| | | | | |
|---|---|---|--|--|
| | <ul style="list-style-type: none"> ▶ Battery clamp condition & tightness ▶ Self-starter (vehicle should start within 5-8sec). Tie rod end play(Within 20 to 30 mm) | <ul style="list-style-type: none"> ✓ ✓ | | |
| 3 | <u>Tyre Condition & Under Carriage:</u> a) Resoling /rethreading/surface plain in front wheel is not allowed. b) If central part is at/thread depth less than 1 inch-Not ok(Only trailer may be allowed for single tyre problem. Supporting tyre to be ok). c) Centre part of the tyre should not be at. d) Any kind of side cut not allowed-depth more than ½ inch not allowed e) Air pressure-Min 7kg/CM2 (Visual Checking). | <ul style="list-style-type: none"> ✓ ✓ ✓ ✓ ✓ | | |
| 4 | <u>R.U.P.G / S.U.P.G:</u> a) 550MM height from ground b) Distance From horse (Cabin side)-500 mm. c) Distance from Rear Tyre-300mm | <ul style="list-style-type: none"> ✓ ✓ ✓ | | |
| 5 | <u>Brakes:</u> a) Foot brake (Service brake) b) Hand brake/Parking brake(No loose of brake chamber stud) c) Fail safe brake (It will work when air fall below 6.0 kg/cm2). d) Trolley brake in working condition (If applicable). e) Leakage from wheel brake actuators & hoses. | <ul style="list-style-type: none"> ✓ ✓ ✓ ✓ ✓ | | |
| 6 | <u>Others:</u> a) Alcohol Checking b) Driving License c) Diesel Level | <ul style="list-style-type: none"> ✓ ✓ | | |
| 7 | <u>Ensure safety during Transportation —If Applicable</u> a) Fixing Proper Wedge. b) Side guard/post. | | | |

| | | | | |
|----|---|--|--|--|
| | <p>c) Welding of clut, wedge.</p> <p>d) Fixing of ag & caution light.</p> | | | |
| 8 | <p><u>Chain: (Only For Trailers)</u></p> <p>a) All link chains of 16 mm dia. Of iron / 12mm dia. Of steel (Test load = 6.3 t) as per IS 2429.</p> <p>b) The chain shall be free from bent, twisted, damaged or cracked links.</p> <p>c) Chain should not be hammered.</p> <p>d) It must have Valid TPI certi cate & No. of chain :03.</p> | | | |
| 9 | <p><u>D shackle:</u></p> <p>1.D Shackle: D shackle of ¾”dia</p> <p>2.Hook of 16mm dia</p> <p>3.Locking pin: ¾” dia</p> | | | |
| 10 | Turn buckles of dia. 1 & 1/2 “ diameter (38 MM) (test load = 6.3 t) as per IS 3121 | | | |
| 11 | Vehicle is without modification of body or cabin to add storage tanks, container etc which can interfere with gross tare weight by adding or emptying the liquid in it before gross/tare and thus interfere with net weighment. | | | |

For permanent gate pass

Sign. Of Vendor Representative _____ Vehicle Fitness Validity Up to _____ Sign. Of TSL representative _____

A.: Material details

| Lot No | MATERIAL NUMBER | MATERIAL DESCRIPTION | QUANTITY | UOM | GST % | TCS % | LOADING charge | Location | Plant Code | Auction Type |
|---------|-----------------|--|-------------------|-----|-------|-------|----------------|----------|------------|-----------------------------------|
| TSLSD/1 | 140000239 | IRON OXIDE - CRM - (Stock + Arising) (2 unit x 50) | 100 (2 unit x 50) | MT | 18% | 0.1% | 150 | 23/4 SBD | 776 | Yankee |
| TSLSD/2 | 146000981 | Rejected Used Sheet Scrap (with masculine/patnale) - (Stock) | 5 | MT | 18% | 1% | 150 | Pilkuwa | 8214 | Dynamic Seal Bid with SBP visible |

Loading Charge Rs.150 /MT in case of QTY in MT and Rs.0.15/ KG in case of QTY in KG

• **Instruction for Bidder: -**

1. No TC shall be provided along with material.
2. Material not to be treated as prime / sold as prime.
3. Material to be delivered on “As is where is basis, No pick & choose allowed”

NOTE: There is no specific size and material to be given from one side & on, as is condition as per the catalogue photos.

Quantity mentioned above is indicative.

- **Intra state Sale: - CGST & SGST: 50% each of GST Rate.**
- **Inter state Sale: - IGST: GST Rate as applicable.**

It is the responsibility of the buyer to furnish the valid GST no. & necessary documents to Mjunction before participating in the auction. In case during the transactions, it is found that valid GST no. has not been provided, then all necessary liabilities if any & so accrued would be on account of the buyer. TATA Steel TSL & Mjunction would not be responsible for any such liabilities.

➤ **Customers are advised to get their Drivers Vaccinated – Vehicles with Driver will only be allowed in the plants for taking delivery of the material when Drivers should be fully vaccinated, on vehicle will be allowed if Driver were not fully vaccinated.**

- (a) * **Material is offered on “AS-IS-WHERE-IS” and “NO-COMPLAINT” BASIS. Material Specification and Photographs if any given in the catalogue is indicative only. The offer is subject to availability of material at Tata Steel TSL.**
- (b) Note: TSL reserves the right to track IP address, MAC number and geolocation of bidding customers whenever customers participate in any auction on the mjunction auction platform for TATA Steel TSL. Further, Customers are requested to install the necessary apps in the devices we use for log in and bidding in mjunction auction platform to enable tracking of the MAC number and geolocation.

B: Payment and Lifting Schedule:

| PAYMENT SCHEDULE (No. of working days from the next date of Lot Confirmation) | | | | | LIFTING SCHEDULE (No. of working days from the next day of Delivery Order release date) | | |
|--|--------------------------|--|---|---|--|-------------------------------------|-------------------------------------|
| Lot No. | EMD (in working days) | 1 st Installment (in working days) | 2 nd installment (in working days) | 3 rd Installment (in working days) | 1 st Installment Lifting Days | 2 nd Installment Lifting | 3 rd Installment Lifting |
| Lot No 1 | | 100 % payment of Lot value within 2 working Days | | | In 4 working days | | |
| Lot No 2 | | 100 % payment of Lot value within 1 working Days | | | In 2 working days | | |

Additional document requirement:

- a. Buyer's/Customer's to send request mail in below format to email id kumar.tulit@mjunction.in & tsmptoms@mjunction.in for issuance of loading Slip along with soft Copy of Driving license of Driver and RC Soft Copy for the updation in tata Steel VTS. This requirement is mandatory for all the customers for the further processing of issue loading Slip.
- b. Original RC and Original DL of Driver etc will need to be produced during vehicle checking at Transport parking (refer point no 6.9 of Catalog terms and condition)

| DO Number | Vehicle Number | Driver Number | Soft Copy RC attached Yes/No | Soft Copy of DL attached Yes/No |
|-----------|----------------|---------------|------------------------------|---------------------------------|
| | | | | |

1. Requirements of participation:

1.1 Registration: Before participation in the e-Auction, a prospective bidder shall be required to get registered with mjunction services limited. For details visit <https://www.metaljunction.com>

1.2 Security Deposit: Non-Interest bearing security deposit of Rs. 60,000/- (Rupees Sixty Thousand only) through Online Payment only: Details as under :

| | |
|------------------|----------------------------|
| Beneficiary Name | MJUNCTION SERVICES LIMITED |
| Bank Name | HDFC BANK LTD |
| Branch Name | Sandoz Branch, Mumbai |
| Account No | Explained below * |
| IFSC Code | HDFC0000240 |

Account No:

All the customers will have a unique account number. The unique account number is an alpha numeric code consisting of 13 characters. The Customer's unique "account number" is a combination of the MJ' SAP code along with the 7 digit bidder SAP ID and can be used as reference for all subsequent transactions. The Customer's Account Number detail is available in "Profile" after the customer logs into our website using the user id and password.

1.3 SPECIAL NOTE: - «\$attributeObject.get(\$!380)»

Attention to All Buyers Participating in TSL-IBMD Auctions

TSL SAP code has been made mandatory for participation in TATA IBMD auctions. Please check your corresponding TSL SAP Code in your profile page. To find the Training Manuals for help, Please go to the tab Training after Login. If you are unable to locate your TSL SAP Code please contact 033-66106150; 8336925968 and 033-66106178 ; 9163348196 for submission of the documents.

“Buyers needs to be careful and serious enough while bidding against any lot, and any bid received by our auction system from the buyer's registered ID will be considered as final bid from that buyer.”

2. Inspection registration & policy :

All parties to send their request for registration of inspection through e-mail to Pankaj Rajput (Pankaj.raajput@mjunction.in) and Aditya Singhal (Aditya.Singhal@mjunction.in) , one day prior to the date of inspection or register themselves by visiting TATA STEEL LIMITED-SAHIBABAD office physically between 9:00AM to 9:30AM on the day of inspection and get their names registered for making gate pass. No one will be entertained beyond 9.30 AM.

(Mail request should contain – Person Name, Firm Name, Mobile No. & Name of the Auction)

Customers are advised to ensure that they inspect the materials on offer on the scheduled date as mentioned in the catalogue, before participating in the auction.

It is reiterated that all materials are offer / sold by Tata Steel TSL on “AS-IS-WHERE-IS” and “NO-COMPLAINTS” basis and no complaint what so ever shall be entertained regarding the quality of materials after the sale. Further, TATA Steel TSL would not accept any claim from any customer for non-inspection of materials” (All interested parties are to report at TATA STEEL LIMITED-SAHIBABAD office between 9.00 am to 9.30 am)

(All are required to bring safety Goggles, Safety Helmet & Safety Shoes. Without the safety equipment's no one will be allowed to inspect the material)

Only registered customers / bidders / representatives of firms shall be allowed for inspection of materials, subject to their fulfilling the safety requirement of the steel works.

Note: Taking photographs and Video of the material is strictly prohibited

“Material Specification & Photographs if any given in the catalogue is indicative only.”

3. Bidding modalities:

3.1 Price Bid Basis: In Indian rupees as per unit of measurement as given in Material List. Price to be quoted is basic, exclusive of all taxes.

3.2 Bid Increment :

3.3 Type of Auction: **Y a n k e e & D y n a m i c S e a l B i d w i t h S B P v i s i b l e .**

3.4 Bid Validity: Bid shall be valid for 15 working days from the date of auction.

3.5 Bid Duration :

4. Taxes & duties:

4.1 Any other taxes & duties: As applicable at the time of dispatch of the materials.

4.2 TCS: As applicable, With effect from 1st April 2021, TCS on sales will be as follows:- TCS on Scraps @ 1% TCS on other goods @ 0.1% In view of above, to facilitate the dispatches buyer are requested to pay the excess amount for the balance quantity or confirm the adjustment in quantity within the deposited amount

4.3 Intra state Sale: - CGST & SGST: 50% each of GST Rate.

4.4 Interstate Sale: - IGST: GST Rate as applicable.

Category Scrap:-

1. This transaction falls u/s 206C(1). Hence Section 194Q will not be applicable.
2. Compliance in relation to section 206AB (Furnishing of I.T Return for past 2 Years) will be taken directly from Income Tax Portal till 28th June-2021. If any compliance made in IT Portal by the customer after 28th June-21, then it shall be communicated to Metal Junction over mail. In case of non-compliance as per section 206AB of Income Tax Act 1961, higher rate of TCS @ 5% will be charged during invoicing.
3. W.e.f 1st of July 2021, invoicing will be done as per new Income Tax provisions.
4. Form 27C & Form 27G shall become inoperative & higher rate of TCS shall be charged, if the customer defaults u/s 206AB of Income Tax Act 1961.

Category Non - Scrap:-

- 1- This transaction falls u/s 194Q. Hence Section 194Q & section 206(1H) shall not be applicable.
- 2- This transaction falls u/s 194Q/206(1H) depending upon the customer's previous year turnover
- 3- Customer has to ensure deduction of TDS u/s 194Q at their end (if applicable). TSL shall not be responsible for any non compliance at customer end.
- 4- To avoid administrative difficulties, the buyer is required to pay full amount against the purchase; and the amount for TDS u/s 194Q shall be paid separately to the Government. The TDS shall be treated as security deposit with Tata Steel Limited and on submission of TDS certificate the same can be refunded/adjusted against future purchases. Illustration showing TDS amount payable.

Refer the below example for TDS computation assuming the sales has crossed the minimum threshold limit

$$\text{TDS payable} = \frac{\text{Amount paid to TSL}}{(100-0.10\%)} \times 0.10\%$$

Example:-

- 5- In case the buyer has not submitted the declaration w.r.t turnover prior to the date of auction, then TSL will assume the turnover to be <10 Cr & TCS @ 0.1% will be collected accordingly during invoicing

- 6- Compliance in relation to section 206AB (Furnishing of I.T Return for past 2 Years) will be taken directly from Income Tax Portal till 28th June-2021. If any compliance made in IT Portal by the customer after 28th June-21, then it shall be communicated to Metal Junction over mail. In case of non-compliance as per section 206AB of Income Tax Act 1961, higher rate of TCS @ 5% will be charged during invoicing.
- 7- W.e.f 1st of July 2021, invoicing will be done as per new Income Tax provisions.

IMPLEMENTATION OF TAX COLLECTED AT SOURCE (TCS) ON SALE OF GOODS WITH EFFECT FROM October 1, 2020

Finance Act 2020 introduced a new Section 206C (1H) for extending the scope of Tax Collected at Source (TCS) on sale of any Goods with effect from 1st of October 2020. Hitherto, TCS was only applicable on sale of certain specific category of goods e.g., Scrap, Coal etc.

The salient features of section 206C (1H) are briefly enumerated below-

1. The rate of TCS is 0.075 percent with effect from 01.10.2020 (0.1 per cent with effect from 01.04.2021). Where the customer has not provided either PAN/Aadhaar, the rate shall be 1 per cent.
2. TCS shall be collected on the consideration in excess of Rs. 50 Lakhs in a financial year.
3. TCS shall not be collected under this section, if it is covered by any other provision of TCS/TDS under Income Tax Act. For example – TCS on Coal, Scrap.

In view of above amendment TCS component will be incorporated in all our sales invoices and Debit notes after GST component i.e., TCS will be computed on total invoice value inclusive of GST. You are requested to process payment of the Sales Invoice inclusive of the TCS component. Such TCS component will appear in 26AS at the end of the quarter and necessary TCS Certificate as per Income Tax Act will be issued.

Note: In case of Scrap & Coal by product sales also (where the current provision of TCS @1% is applicable), TCS will be incorporated in the sales invoices & Debit Notes.

Customers are required to submit Form 27C/Form 27G against the month of dispatch/expected dispatches. In the absence of Form 27C, TCS will be charged at the time of invoicing.

Refund on account of TDS u/s 194Q:-

In order to claim the refund of the TDS deposited u/s 194Q while making the payment to Tata Steel Limited, you are advised to send the necessary details as per the below format to our O2C Collection Team (Mail ID - o2c.collection@tatasteel.com) along with TDS Certificate*.

| Customer Code | Customer Name | PAN Number (**) | TDS Amount (as per TDS Certificate u/s 194Q) ** | Period of TDS (Quarter)** |
|---------------|---------------|-----------------|---|---------------------------|
| | | | | |

***TDS Certificate must include**

- Duly downloaded from Income Tax site mentioning Period (Qtr), TAN No of Deductor (Customer), Name of Deductor (Customer), Amount of Transaction & TDS
- Duly digitally signed by authorized person
- Nature of Payment -194Q
- Deductee- TATA STEEL LIMITED

**** PAN No , TDS Amt (194Q) , Period are available at TDS Certificate itself**

5. Payment terms & conditions:

5.1 Payments:

- EMD & Installment payments shall be accepted only by RTGS/NEFT.
For details please contact 033-44091801

5.2 EMD: As mentioned in Payment and Lifting schedule.

5.3 **Delay payment charges (DPC) Installment payments with DPC @five (05) paise per Rs. 100 per day will be accepted up to Two (02) working days from due date of installment payment as mentioned in the confirmation letter. GST @18% would be charged in addition to the above DPC amount. Additional grace period is not applicable for EMD payment.**

5.4 Only Sundays are excluded for counting purpose for payment schedule

- 5.5 In the event of Non-Receipt of Payment within the stipulated period of Payment, the Sale Offer for the approved Lot shall stand withdrawn automatically.
- 5.6 TIN of TSL : 21681400935
- 5.7 Second and Fourth Saturday of month is excluded for counting purpose of payment schedule as per notification of RBI.
- 5.8 Buyers has to submit EMD & Installments payment in below Virtual Account of TSL as per below :-

| | |
|-------------------|-------------------------------|
| Beneficiary Name | TATA Steel Limited |
| Bank Name | HDFC Bank Ltd |
| Branch Name | Kanjurmarg |
| Account No | 3344(TSL SAP code for IBMD) |
| Account Type | Virtual Account code |
| Centre (Location) | Mumbai |
| IFSC Code | HDFC0000240 |

Please check your new virtual code under the tab Post Auction > Client RTGS A/c Details > Click on IBMD > Select Sub Org: Tata Steel (TSL).
In case of any issue, you may please contact at 8336901082 / 7596096008

6. Lifting terms & conditions:

- 6.1 DOs will be handed over to authorized representatives of bidders on receipt of payment.
Lifting date is calculated from the next date of DO release.
- 6.2 Loading Charges: As per material annexure
- 6.3 Loading shall be given strictly as per the statutory norms & safety norms of Tata Steel Ltd.
- 6.4 Loading Days: Lifting will be given on all days of the week including Sundays. However, Sundays are excluded for counting purpose for lifting schedule.
Loading shall be given strictly as per the statutory norms & safety norms of Tata Steel TSL.
- 6.5 Lifting with Ground Rent (GR): Lifting along with GR will be allowed up to 4 working days from the last date of lifting period. Ground Rent will be calculated on Basic value of balance unlifted quantity @05 paise per Rs 100 per day. GST @18% would be charged in addition to the above Ground rent amount.**
- 6.6 DO validity can be extended Only ONCE against each Delivery Order upto a maximum of 4 days from last date of original validity period of the DO ,subject to receipt of GR Payment through online only by 01.00 PM on the first working day after the expiry of the Original validity period of DO. Kindly note that all the Delivery Orders (DO), which meet the Lot Closure Norms, shall be closed within one day from the date of expiry of original Delivery Order (DO) validity**
- 6.7 Additional lifting days for advance payment of installment - If the installment payment is made in advance, then additional lifting days (equivalent to the number of days payment made in advance) would be given.
- 6.8 Suitable extension of due date for payment and lifting will be accorded in case of any eventualities like Strike/ Bundh / Special restriction on vehicular movement imposed by the local Admn. Etc

6.9 Documents for verification regarding entry of vehicles inside Tata Steel TSL works :

All customers to note that presentation of following set of documents to TATA STEEL TSL authorities is COMPULSORY at the time of reporting of vehicles at TSL designated Gate for entry of Customer trucks/vehicles.

- a. Driving License of driver,
- b. Registration Card,
- c. Commercial Certificate,
- d. Fitness Certificate of Vehicle,
- e. Re-registration for vehicles older than 15 years
- f. Insurance

The checklist form will be filled in at TSL designated Gate for entry of Customer trucks/vehicles before entry of vehicle.

6.10 Weighment: Weight recorded by Tata Steel weighbridge will be considered final and binding on the customer.

7. Penalties:

7.1 The following penalties shall be applicable in the eventuality of a buyer defaulting in making the payment of EMD (wherever applicable) or first (Single)- installment, as per the stipulated schedule for each lot, in a financial year:-

- In the first instance, a penalty of Rs. 60,000/- (Rupees sixty thousand only) shall be recovered from the customer. The above penalty amount would be inclusive of GST amount @ 18%.
- In the second instance, a penalty of Rs. 1,20,000/- (Rupees One Lakh twenty thousand only) shall be recovered from the customer. The above penalty amount would be inclusive of GST amount @ 18%.
- In the third, and any subsequent instance, a penalty of Rs. 1,80,000/- (Rupees One lakh eighty thousand only) shall be recovered and the customer shall be debarred from participating in any auction for a period of three months from the date of debarment. The above penalty amount would be inclusive of GST amount @ 18%.

In the event of any of the above mentioned default, the customer's user id will be disabled and the customer will be blocked from participating in any auction of TSL with immediate effect.

Post default, customer shall be allowed 06 (Six) working days to deposit the penalty as mentioned above. In case the penalty is not received within the stipulated period, the customer's security deposit shall be forfeited and above mentioned debarment from participating in any auction of TSL would continue.

In the event of any above-mentioned default, the customer's user id will be disabled and the customer will be blocked from participating in any auction of TSL with immediate effect.

7.2 If, after making payment of EMD (wherever applicable), the installment payment/s are not made by the customer as per the stipulated schedule for each lot, the entire EMD amount against such lot shall be forfeited.

7.3 In case of non- lifting of full lot quantity after making full payment, a penalty equivalent to 20% of the basic material value for the unlifted confirmed quantity against each lot shall be recovered from the customer. GST @18% would be charged in addition to the above penalty amount.

8. Lot Closure Norms :

For Lot Closure, the tolerance would be $\pm 20\%$ or at Seller's Option

9. Refund :

9.1 "TATA Steel TSL would make refunds only through online mode wef 15th June 2016. All customers are required to submit necessary details to Mjunction by 15th June."

9.2 Refunds will only be made by TATA Steel TSL vide RTGS/NEFT and hence all customers are required to submit their bank details to mjunction or mail at mjbpo.group@mjunction.in. TATA Steel TSL or mjunction will not be responsible for any delay in refunds owing to absence of bank details of the customer.

10. Complaints :

Complaints, if any, with regard to any transaction, shall have to be lodge by the buyers within three Months from the date of last invoice. No complaint shall be entertained thereafter, under any circumstances. **Customers can log their complaints at fsc@mjunction.in or can log in CCHP (Turant Upaay).**

CCHP Log in Manual: https://www.metaljunction.com/appuploads/file/metaljunction/Bidder_Manual_CCHP.PDF

11. Jurisdiction :

Any dispute arising out of any contract shall be decided in Jamshedpur by the courts in Jamshedpur and by no other courts. The courts in Jamshedpur shall have exclusive jurisdiction to adjudicate upon any such dispute.

12. General terms & conditions:

12.1 No claims on quality of material and bid cancellation shall be entertained at any point of time after the auction.

12.2 The quantity indicated is on "as- is- where- is- basis" and "no- complaint basis", and "subject to availability" of material.

12.3 Lot transfer will not be allowed. Payment and invoicing has to done in the name of the H1 bidder, subject to the prices being approved.

12.4 Material purchased should be the only material being lifted from the designated location. Tata Steel TSL has the right to check any vehicle at any moment of time.

If material lifted differs from the material, the buyer purchases that, and then the buyer/authorized representative will be permanently debarred. Also Tata Steel can take any penal action against the buyer/authorized representative. All the material loaded in the vehicle is to be covered in order to follow the safety compliance of Tata Steel TSL works. If the safety compliance is not followed then Tata Steel TSL can penalize the buyer/authorized representative as deemed fit. GST @ 18% would be charged in addition to the above penalty amount

12.5 Customer attested photocopy of valid photo ID proof (Voter ID/PAN/Aadhar Card) of all lifters/authorized persons engaged by customers for lifting of scrap from TSL is to be enclosed with the authorization letters to be forwarded to TSL (Security/MRSPP) for issue of Gate Pass.

12.6 Dispatch is subject to Force Majeure Conditions.

12.7 The Seller reserves the right to terminate this offer without assigning any reason.

12.8 In the event of termination of the offer, Seller shall refund the balance amount after due reconciliation.

12.9 Material is being sold on "As Is Where Is" & No Complaint basis.

12.10 No claims whatsoever would be entertained after cancellation of the bid.

12.11 Wearing proper PPE at all times when inside the plant

12.12 NO driver to be roaming around during loading of vehicles

12.13 Scotch blocks mandatory when under loading or when at halt

12.14 Drivers to be only at designated areas during loading.

12.15 All vehicles to follow ONLY designated route inside the plant as per instruction given at gate.

12.16 Vehicles to be parked only at designated areas. All lifters to discuss the same with plant Operations under any confusion

12.17 No speed violation is acceptable under any circumstances

13. Compliance to safety norms

13.1 Authorized persons (of the customer) involved in lifting of the materials will be allowed only with Personal Protective Equipment's (PPE) i.e., Safety Shoes, Safety Helmet, Safety Goggles, Fluorescent Jacket and Hand Gloves.

No "people movement" shall be allowed at the time of loading/delivery of materials from the yards"

Tata Steel TSL will not be responsible for any delays arising out of Non- Compliance to the Safety Norms.

1. All driver & operator will wear the Safety Helmet. Safety Shoe, Safety Goggles & FR Jacket
 2. Vehicle should be parked as per TSL standards (Use of scotch block etc)
 3. All will use Safety belt while walking or checking of level
 4. Reverse buzzer must be available and in working condition. It must be fitted with the reverse gear (No separate switch/control should be with Driver).
 5. Vehicle drivers and all crew members/Supervisors must be in a safe place that is away from the vehicle while loading/unloading is being carried out.
 6. It should be ensured that while placement of vehicle, loading & un-loading activity and reversing, no men should be around the 10 m of the vehicle.
 7. For such vehicle Loading/Unloading activity must be carried out under the supervision of TATA STEEL TSL.
 8. SOP for the loading/Unloading activity must be prepared and hazards while reversing of the vehicle must be mentioned. Crew must be trained on SOP.
 9. For CRFH Coilend - vehicles steel body or steel framed dala vehicles to be placed for ensuring no deformation in dala after loading pup coils. Non complying vehicles will be returned during safety check.
 10. In NO case the driver should climb on top of the vehicle cabin roof/dala edges when vehicle is inside plant premises, on road or at loading point. For any such activity tarpaulin covering shed to be used.
 11. Special instructions given to driver at safety induction point to be followed strictly till the vehicle is inside the plant premises.
 12. For any difficulty or support needed, IBMD Operation team to be contacted (telephone no. mentioned on the loading slip)
- In case drivers don't follow safety norms repeatedly, despatch to the concerned customer will be discontinued and reviewed suitably.
13. Vehicles for material lifting will only be allowed to enter in plants when Drivers must be fully Vaccinated.

13.2 "USE OF HYDRA CRANES BY CUSTOMERS IN ANY PREMISES/LOCATION /STOCKYARDS OF TATA STEEL LIMITED-SAHIBABAD AND ITS VENDORS/CONSIGNMENT AGENTS' PREMISES IS BANNED".

13.3 In addition to earlier safety norms, the following would be compulsory w.e.f 15th June '2014 :

The drivers of the vehicle must have the eye test certificate. The frequency of the testing would be as below :

1. If the age of the person is less than 45 years - Once in a year
2. If the age of the person is 45 years or more, the testing is required to be done once in every 6 months

Please ensure to comply with the safety norms

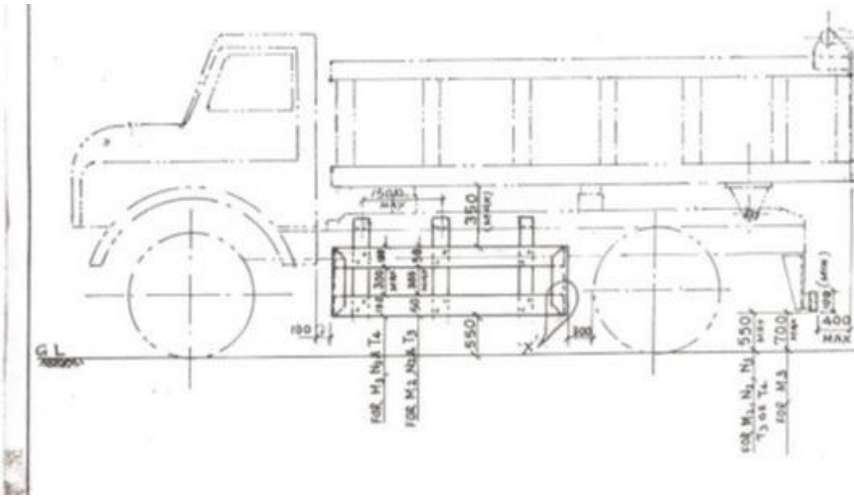

Frr--r

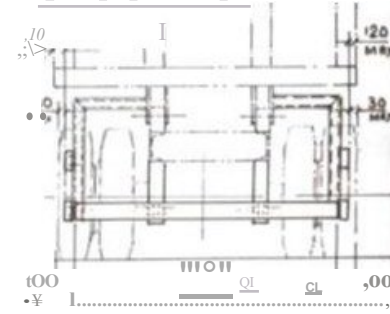

d

Lait.RAL PROTE.CiOt-1 &
REAR UI-IDE.R.N PROTEC.I\VE. DE.VICE

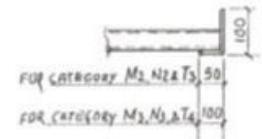

ENLGD DET - X

Signature
 17/12/09

Safe Loading & Transportation of Pup Coil

Do



The loading of coils is within dala height.
Retaining tail board is fixed.

Don't



The loading of coils is above dala height.
Retaining tail board not fixed.

Covid19 Check sheet - Vendor Driver of Trailer /Truck

Truck /Trailer No. :

Material Dispatch Date:

| | | | | |
|---|---|---|---------------|---------------|
| | Vendor Name / Code: | Material Dispatch Time: | | |
| | Type of Material Carried : HR/CR/SLAB/BILLET/Others | | | |
| | | Material Dispatch Location (Full Address): | | |
| S. No. | Points to be checked | Ok | Not Ok | Remark |
| 1 | Driver last 14 days temperature and health check (Please attach Temperature/ health record). Fill Annx 1 Not allowed to enter TSL-SAHIBABAD if Temperature > 98.6 F To be separately filled for Driver | | | |
| 2 | Driver/ Representative wearing necessary PPE – Mask and Gloves. | | | |
| 3 | Driver wearing Safety shoes & Full PPE (no torn allowed). | | | |
| 4 | Driver wearing full clothes (Covering full legs and hands till wrist) to minimize exposure. Recommendation from MSIL | | | |
| 5 | Truck to be sanitized before every trip (To be checked and signed seal by vendor security in charge). | | | |
| 6 | All commercial documents to be put in a sealed envelope to avoid multiple touch points. | | | |
| 7 | Driver already trained on social distancing and also taught not to stop anywhere en route. | | | |
| 8 | Bins/ Trolleys/ Other reusable packaging carrying material has been sanitize. | | | |
| 9 | Truck Cabin equipped with Hand Sanitizer | | | |
| 10 | Driver and Codriver to remain in truck (Except loading/ unloading of material and material gate) | | | |
| 11 | It is recommended to bring packed food along.(Due to restriction of movement in plant) | | | |
| Note - Please do not send driver co-driver | | | | |
| | Any other Point अन्य : | | | |
| | Truck Driver Codriver Signature | | | |
| | Vigilance/ Safety In charge Signature and Seal | | | |
| | Logistics Manager Signature and Seal | | | |
| | Note - I have checked above details thoroughly and found are ok as per my best knowledge. | | | |

VEHICLE CHECK LIST-TRANSPORT PARK

| | |
|---------|--|
| TRUCK | |
| TRAILOR | |

Vehicle No. _____

Date : _____

| SL. NO. | CHECK POINT | YES | NO | REMARKS |
|---------|---|-----|----|---------|
| 1 | Body condition and cleanliness | | | |
| 2 | Seat Belt | | | |
| 3 | Driving Licence (and crew member licence if applicable) | | | |
| 4 | Three piece mirror with proper adjustment/scotch block | | | |
| 5 | PPE | | | |
| 6 | Hand break/parking break | | | |
| 7 | No oil Leakage | | | |
| 8 | Vehicle head light, back lights and blinkers | | | |
| 9 | Horn working condition | | | |
| 10 | Reverse horn working condition | | | |
| 11 | Number plate (Clear/Visible as per M. V. Act) | | | |
| 12 | Foot Rest (Physical Condition) | | | |
| 13 | Fail Safe Break | | | |
| 14 | Indicator light with audible buzzers are in working condition | | | |
| 15 | Tyre condition/Pressure and other | | | |
| 16 | Run under protection | | | |
| 17 | Chain : No. of 3 Pic chain as per standard (12mm Dia) | | | |
| 18 | D shackle as per standard (3/4 Dia) | | | |
| 19 | Turn buckle as per standard (38mm) | | | |
| 20 | Rubber Pad | | | |
| 21 | Dunnage | | | |
| 22 | RUPG/SUPG | | | |

Name _____

Date _____

Signature _____

NOTE : Measurement of Sl. No. 21 & 22 on back side

1st Jan

Vehicle –Accepted / Returned for rectification (√)

Signature of the Inspector-

Name-

Name of Service provider-

Note : ***

Signature of Vendor/Transporter

Name-

Name of Vendor/Transporter -

1. The Tanker driver and the helper who is coming with the vehicle should be knowledgeable about the levels of the Tanker.
2. Tanker should come with the Calibration certificate for checking and ensure the proper levels and Tonnages.

METHODOLOGY FOR ALLOCATION OF QUANTITY IN YANKEE BIDDING

Allocation is carried out by the e-Sale software on following basis:

- a) First preference is given to highest bid price
- b) If two or more parties bid the same price then preference for allocation is given to party that placed the bid for a higher quantity.
- c) In case two or more parties bid the same price and quantity, then preference is given to the party that placed the bid earlier.

The above is illustrated below for tonnage wise bidding.

Assume that the total quantity available is 800 mt. and customers bid for certain quantity (in MT) at a certain price as illustrated in following table (minimum bid quantity is assumed as 200 MT= 1 UNIT):

| Bidder | Bid Time (Hr.: Min.) | Bid Quantity in Units (200MT= 1UNIT) | Bid Price (Rs/Unit) | Allocated Qty. In Units (200MT = 1 UNIT) |
|--------|-------------------------|---|------------------------|--|
| B | 9.40 | 1 | 15000 | 1 |
| F | 9.39 | 2 | 14800 | 2 |
| D | 9.36 | 1 | 14800 | 0 |
| A | 9.32 | 1 | 14800 | 1 |
| E | 9.34 | 1 | 14800 | 0 |
| C | 9.30 | 2 | 14750 | 0 |

Explanation for the Allocation of Quantity

1. Bidder B is the highest bidder @ Rs.15000/MT, hence the system allocates his bided quantity i.e., 200 mt = 1 Unit
2. There are 4 bidders @ Rs.14800/Mt.
 - I. Since bidder F's bid was for 400 MT (2 Unit) (Highest at Rs.14800/MT) the system allocates his bid quantity in full.
 - II. Since bidder A placed his bid earlier than bidder D & bidder E i.e. 9.32 Hrs hence the software gives first preference to Bidder A
 - III. and allocates bidder A the available quantity (i.e. 200 MT = 1 Unit) first.
3. Since, all the quantity is exhausted at higher bid price than Rs.14750/MT, therefore no quantity is allocated to Bidder C. If Bidder C wants to win any quantity then he has to place bid in terms of higher price and/or greater quantity.

Vehicles Entry Rule In view of Covid -19

1. At the testing centre, travel history of driver and customer representative with valid gate pass is to be submitted for testing slip to be issued. Without proper declaration of travel, testing slip would not be issued which is a mandatory document for entry inside works
 2. It is mandatory to have Aarogya Setu Application installed in the mobile or IVRS verified in case personnel does not have smartphone, and would be duly checked at the testing centre
 3. Customer representative with valid gate pass and driver should have the adequate PPEs including Face Mask and gloves for entry inside works. Removal of face mask or spitting inside works is strictly prohibited
 4. All personnel are required to get the thermal scanning done at the Testing centre to proceed inside works. If anything abnormal is indicated, the personnel would be directed to the nearest medical facility for further tests
 5. Social distancing is to be followed as per the issued government guidelines and must be ensured at all places, including inside works and Transport Park Area.
 6. All the catalogues would be uploaded along with the videos and photographs of the lots and should be referred to understand the quality of the lots. Any request for physical inspection for the material would not be entertained
 7. No visitor gate pass would be issued to any personnel for entry inside works until further notice
- In addition to above clauses, for customers visiting SPC/EPA facility regarding inspection of material - Proper PPEs including face mask and gloves are mandatory for customers during inspection of material at the EPA Facility. EPAs would not allow the entry of personnel in case the above conditions are not met

Declaration to be submitted for all the authorized representative as per the format

In view of Covid 19, it is compulsory to attach the below details as per format for each of authorized representatives along with the lifting authorization letter for each lot/Delivery order. In case the same is not provided along with the authorization letter duly signed by the organization on their letter head, the authorization letter will be considered as incomplete and will not considered for further course of action wrt dispatch of material.

| 1 | 2 | 3 | 4 | 5 | 6 | 7 | 8 | 9 |
|---------|------------------------|-----------|------------|--------|--|-------------------------------|------------------------------------|--|
| Sl. No. | Authorized Lifter Name | Aadhar No | Mobile No. | DO No. | Aarogya Setu Verified (App/IVRS) (Y/N) | Last One month travel history | Contact with a Covid patient (Y/N) | Experiencing any symptoms like fever, dry cough, muscular pain, breathlessness (Y/N) |

Form No.27C
[See Rule 37C]

Declaration under sub-section (1A) of section 206C of the Income-tax Act, 1961 to be made by a buyer for obtaining goods without collection of tax

| <u>PART II</u> (For use by the person to whom the declaration is furnished) | | |
|---|---|--|
| 1. Name of the Seller - Tata Steel TSL Limited | | 2. PAN of the Seller - AAAC2803M |
| 3. Complete Address - 43, Jawaharlal Nehru Rd, Kankaria Estates, Park Street area, Kolkata, West Bengal 700071 REGD. OFFICE - BOMBAY HOUSE, 24 HOMI MODY STREET, FORT, MUMBAI - 400001 | | 4. TAN of the Seller - CALT02940A |
| 5. Email - rohit.agarwal@tatasteel.com | 6. Telephone No. (with STD Code) and Mobile No. 08017055578 | 7. ***Status (Choose among 1 to 6) - Company |
| 8. Date on which declaration is furnished(dd/mm/yyyy) | | |
| 9. Date of debiting of the amount payable by the buyer to the account of the buyer or receipt of the amount payable from the buyer in cash or by issue of a cheque or draft or by any other mode (dd/mm/yyyy) | | |
| Forwarded to the Chief Commissioner or Commissioner of Income-Tax | | |
| Place: Kolkata Date: | Signature of the person responsible for collecting tax at the time of the sale of the goods referred in Part I. | |

Notes:

The declaration should be furnished in duplicate.

*Delete whichever is not applicable.

**Indicate the capacity in which the declaration is furnished on behalf of a HUF, AOP, firm, company, etc.

***1=Company; 2=Firm; 3=AOP/BOI; 4=HUF; 5=Individual; 6=Others

Before signing the verification, the declarant should satisfy himself that the information furnished in the declaration is true, correct and complete in all respects.

Any person making a false statement in the declaration shall be liable to prosecution under 277 of the Income-tax Act, 1961 and on conviction be punishable-

- I. In a case where tax sought to be evaded exceeds twenty-five lakh rupees, with rigorous imprisonment which shall not be less than 6 months but which may extend to seven years and with fine
- II. In any other case, with rigorous imprisonment which shall not be less than 3 months but which may extend to two years and with fine

“Photographs of lots are at best indicative only and do not necessarily reflect the actual condition of lots. All bidders are advised to physically inspect the offered lots before participating in the auctions. Tata steel TSL or MJ shall not be responsible or liable for any error of judgement or bids put by bidders acting on the basis of these photographs.”

ALL THE PHOTOGRAPHS ARE INDICATIVE FOR AUCTION



SHRIRAM INSTITUTE FOR INDUSTRIAL RESEARCH

(A unit of Shriram Scientific and Industrial Research Foundation)

19, University Road, Delhi – 110007 (India)
An ISO - 9001, 14001 & 45001 Certified Institute

Website : www.shriraminstitute.org
E-mail id : customercare@shriraminstitute.org
qad@shriraminstitute.org

TEST REPORT

NO : C1/0000327954

Issued To :
Client Code : (GHAZ01M2586)
MICROSOL CONSTRUCTIONS
474, SECTOR 3F, VAISHALI
GHAZIABAD
UTTAR PRADESH-201010
Kind Attn: MS NEHA

Date : 07-06-2023
Job No : 2305-1-MIN-2045
Booking No : RG2324/1/1664
Booking Date : 30-05-2023
Customer Ref No. : MC/TSL/2905/001
Customer Ref Dt. : 29-05-2023

Sample Description :

ONE SAMPLE DESCRIBED AS IRON OXIDE ; WAS RECEIVED.

Job No : 2305-1-MIN-2045

The sampling was not carried out by SHRIRAM INSTITUTE FOR INDUSTRIAL RESEARCH.

The sample particulars provided in the Test Certificate are based on the declaration by the Customer

TEST RESULT

| S.No. | Parameter | Observation | Protocol/Tec.used |
|-------|-------------------------------|-------------|--------------------------------------|
| 1 | Chloride (as Cl),% by mass | 0.002 | IS:4032-1985 RA 2019 |
| 2 | Copper (as CuO),% by mass | 0.002 | IS:1493-(pt-5)1981 RA 2016 & ICP-OES |
| 3 | Chromium (as Cr2O3),% by mass | 0.04 | IS:1493-(pt-3)1981 RA 2016 & ICP-OES |
| 4 | Sodium (as Na2O),% by mass | 0.07 | IS:1493-(pt-6)1981 RA 2016 & ICP-OES |
| 5 | Bulk Density,gm/cc | 3.62 | IS:33 -1992 RA 2019 |

DOR:30/05/2023
DOS:03/06/2023
DOC:07/06/2023

End of Report

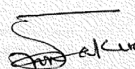
AUTHORISED SIGNATORY
EMPLOYEE CODE:(5117)

GC-01(Rev.05)

1/1

Note: The results relate only to the items tested / calibrated above.
Scanned copies/photocopies or any other copies should be authenticated by reference to the original report.

SRI-C1 (Rev. 05)

Phone : 91-11-27000100, 27667267, 27667860 Fax : 91-11-27667207
See overleaf for terms & conditions



SHRIRAM INSTITUTE FOR INDUSTRIAL RESEARCH

(A unit of Shriram Scientific and Industrial Research Foundation)

19, University Road, Delhi – 110007 (India)
An ISO - 9001, 14001 & 45001 Certified Institute

Website : www.shriraminstitute.org
E-mail id : customercare@shriraminstitute.org
qad@shriraminstitute.org

ULR NO. : TC54442300006584F

TEST REPORT

NO : C1/0000327950



Issued To :
Client Code : (GHAZ01M2586)
MICROSOL CONSTRUCTIONS
474, SECTOR 3F, VAISHALI
GHAZIABAD
UTTAR PRADESH-201010
Kind Attn: MS NEHA

Date : 07-06-2023
Job No : 2305-1-MIN-2044
Booking No : RG2324/1/1664
Booking Date : 30-05-2023
Customer Ref No. : MC/TSL/2905/001
Customer Ref Dt. : 29-05-2023

Sample Description :

ONE SAMPLE DESCRIBED AS IRON OXIDE ; WAS RECEIVED.

Job No : 2305-1-MIN-2044

The sampling was not carried out by SHRIRAM INSTITUTE FOR INDUSTRIAL RESEARCH.

The sample particulars provided in the Test Certificate are based on the declaration by the Customer.

TEST RESULT

| S.No. | Parameter | Observation | Protocol/Tec.used |
|-------|--|-------------|--------------------------------------|
| 1 | Moisture Content (at 105 \pm 2 $^{\circ}$), % by mass | 0.01 | IS:1493-(pt-1)1981 RA 2016 |
| 2 | Silica (as SiO2),% by mass | 0.08 | IS:1493-(pt-1)1981 RA 2016 |
| 3 | Iron (as Fe2O3),% by mass | 99.0 | IS:1493-(pt-1)1981 RA 2016 |
| 4 | Lime (as CaO),% by mass | 0.2 | IS:1493-(pt-3)1981 RA 2016 & ICP-OES |
| 5 | Magnesium (as MgO),% by mass | 0.04 | IS:1493-(pt-3)1981 RA 2016 & ICP-OES |
| 6 | Aluminium (as Al2O3),% by mass | 0.1 | IS:1493-(pt-3)1981 RA 2016 & ICP-OES |
| 7 | Manganese(as MnO),% by mass | 0.2 | IS:1493-(pt-3)1981 RA 2016 & ICP-OES |
| 8 | Phosphorous (as P2O5),% by mass | 0.03 | IS:1493-(pt-1)1981 RA 2016 & ICP-OES |

DOR:30/05/2023
DOS:03/06/2023
DOC:07/06/2023

End of Report

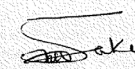
AUTHORISED SIGNATORY
EMPLOYEE CODE:(5117)

GC-01(Rev.05)

1/1

Note: The results relate only to the items tested / calibrated above.
Scanned copies/photocopies or any other copies should be authenticated by reference to the original report.

SRI-C1 (Rev. 05)

Phone : 91-11-27000100, 27667267, 27667860 Fax : 91-11-27667207
See overleaf for terms & conditions



Rejected Used Sheet Scrap (with masculine/patnale)



